

■ Basic specifications and operating range

[Manipulator Specifications]

Note 1) Position repeatability of the tool center point (TCP) value complies with the JIS B 8432 Standard.  
 Note 2) Regarding the specification of the operation speed, a risk assessment in the use environment is required.

Item		Specification	Specification
Name		NVC4	NVC4L
Structure		Vertically articulated type	Vertically articulated type
Number of Axes		6	6
Wrist Capacity		8.81lb (4 kg)	8.81lb (4 kg)
Positional Repeatability		± 0.03mm (Note 1)	± 0.04mm (Note 1)
Drive Method		AC servo motor	AC servo motor
Drive Capacity		800 W	800 W
Position Feedback		Absolute encoder	Absolute encoder
Working range	Arm	J1 (Rotation)	±170°
		J2 (Front/Back)	-155°~+90°
		J3 (Up/Down)	-155°~+180°
	Wrist	J4 (Swing)	±170°
		J5 (Bending)	-30°~+210°
		J6 (Twist)	±360°
Maximum Speed		39 in/s (Note 2)	39 in/s (Note 2)
Wrist Allowable Load	Allowable moment	J4 (Rotation)	13.0 N·m
		J5 (Bending)	13.0 N·m
		J6 (Twist)	4.4 N·m
	Allowable Moment of Inertia	J4 (Rotation)	0.462 kg·m <sup>2</sup>
		J5 (Bending)	0.462 kg·m <sup>2</sup>
		J6 (Twist)	0.048 kg·m <sup>2</sup>
Arm Cross-section Area		15.2ft <sup>2</sup> (1.41 m <sup>2</sup> ) × 340°	32.7ft <sup>2</sup> (3.04m <sup>2</sup> ) × 340°
Environmental Conditions		Temp.: 32°F to 113°F (0 to 45°C), Humidity: 20~80%RH (No-condensation)	Temp.: 32°F to 113°F (0 to 45°C), Humidity: 20~80%RH (No-condensation)
Weight		82lb (37kg)	104lb (47kg)
IP code		IP65	IP65
Installation method		Floor-mounted	Floor-mounted
Paint color		Ice Blue	Alice Blue

[Manipulator Working Range]

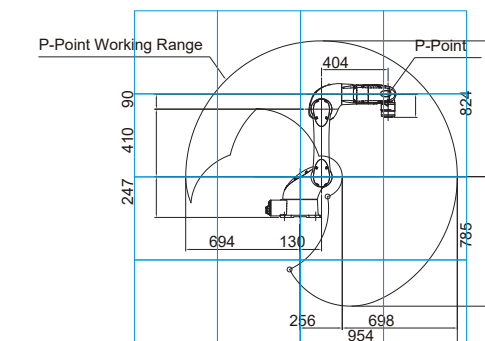
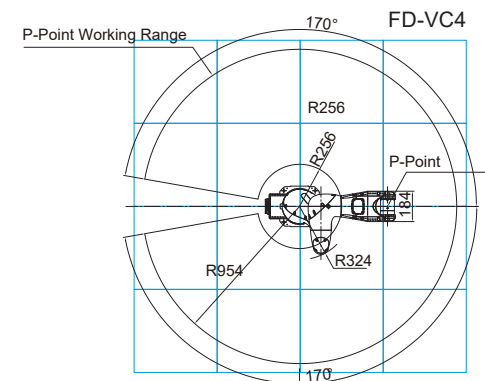

P-Point Working Range FD-VC4L

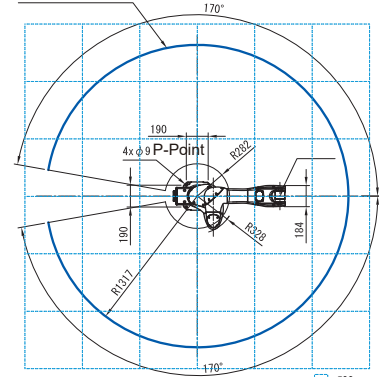

P-Point Working Range

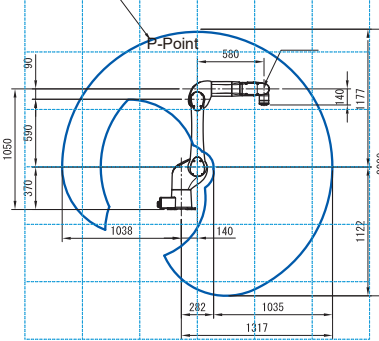

DAIHEN Inc.

*Friendly series II*

**The Optimum Robot  
for Collaborative Arc Welding**  
**FD-VC4 FD-VC4L**



**Multiple Easy Teaching Methods  
with the Latest in Welding Technologies**

Optimum robot  
for collaborative arc welding with high track accuracy  
and high durability!



OTC DAIHEN Website  
www.DAIHEN-USA.com

**NORTH AMERICA CORPORATE HEADQUARTERS**

1400 Blauser Dr, Tipp City OH 45371  
Phone: (937) 667-0800  
Fax: (937) 667-0885

DAIHEN ROBOT Website  
www.DAIHEN-robot.com/en

**ATLANTA TECHNICAL CENTER**

3135 Medlock Bridge Road  
Norcross, GA 30071  
Phone: 888-OTC-ROBO  
Fax: (937) 667-0885

**DETROIT TECHNICAL CENTER**

750 Welch Road  
Commerce Township, MI 48390  
Phone: 888-OTC-ROBO  
Fax: (937) 667-0885



Member of DAIHEN Group

In accordance with DAIHEN's policy to make continuing improvements, design and/or specifications are subject to change without notice and without any obligation on the part of manufacturer.

OTC-28 REV 08/24

# DAIHEN Robots Solve the Problem of Collaborative Arc welding applications

## Optimum Robots for Collaborative Arc Welding

### Quality

Achieves high track accuracy enabling high quality welding

Collaborative robots with low trajectory accuracy may cause welding defects as shown in the figure on the right. DAIHEN, the Global Leader in Robotic Arc Welding Technology, has developed a new control technology to improve the trajectory accuracy of linear and circular interpolation, which improves welding quality, and installed in the Optimum Robot for collaborative applications. Achieves high-quality welding with stable trajectory accuracy equivalent to that of industrial robots.

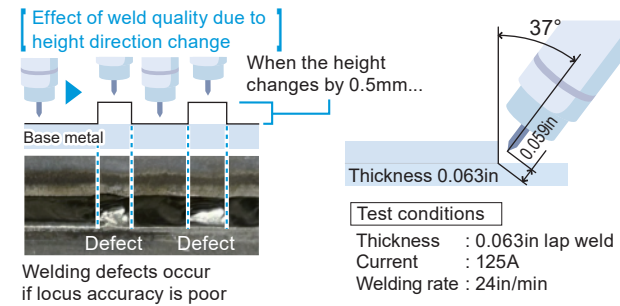

### Teaching

Easy to teach the target position with touch sensor mode  
Directly move the arm by hand to teach the welding start position and aiming posture

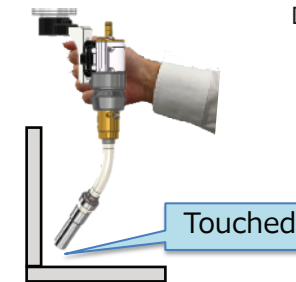

- Robot stops automatically when wire touches base material.
- The target welding position can be taught accurately and easily.
- Automatic stop function prevents interference between the base material and the torch due to operational errors. (Optional Touch sensor software required)

### Use

Various welding methods are selectable

CO<sub>2</sub>/MAG welding

MAG pulse welding

Low-Spatter welding

Ultra-Low-Spatter Technology Synchro-feed robotic welding system

TIG welding

By adopting the same controller as an industrial robot, a wide variety of peripheral devices and functions can be used. Various welding methods such as CO<sub>2</sub>/MAG welding, ultra-low spatter welding, and TIG welding can be selected to suit the application. A full range of welding functions can be used, so they are capable for all welding tasks.

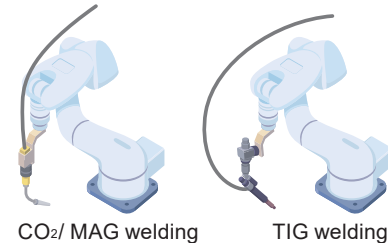

#### Extensive welding-only functions

- Touch sensor function
- Arc sensor function
- Weaving function
- Offline Teaching System D-ST
- Robotic Welding Management-System FD-AM
- Various welding torches

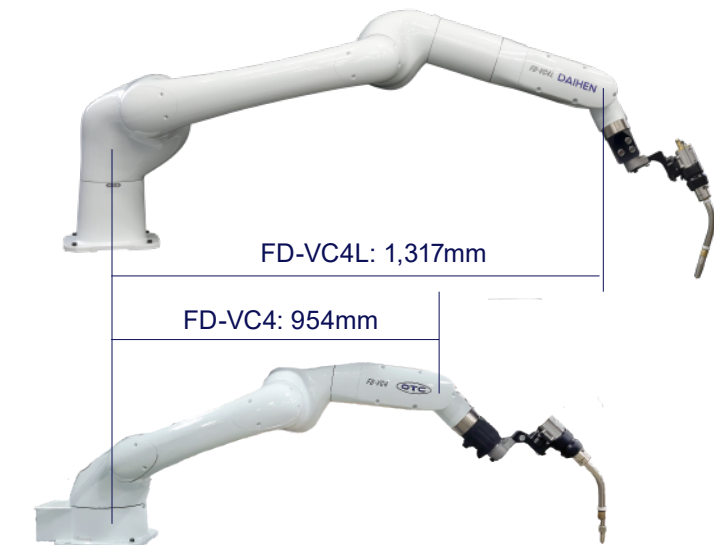

### Space Saving

No need for a safety fence to separate people and robot.

This optimum robot for collaborative application can work in the same space as a person without installing a safety fence.\*1

Therefore, it is no longer necessary to secure a large space for introduction of conventional industrial robots.

\*1 If a safety fence is not installed, a risk assessment by the customer is required.

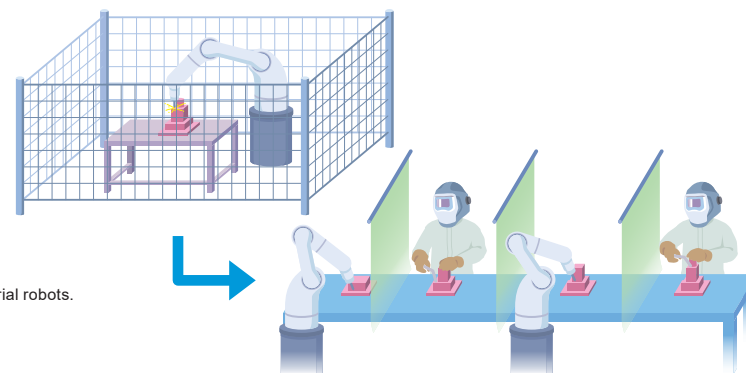

FD-VC4 and FD-VC4L complies with ISO 10218-1 safety standard for industrial robots. In addition, the Robot Controller conforms to the international standard "ISO 13849-1PLd(Cat.3)" and safety certification by a third-party certification body has acquired.

### Safety

When contact with a human is detected, the robot stops.

This optimum robot is equipped with a safety function that automatically stops when a force exceeding a preset contact level is detected. In addition, it has an arm shape that prevents pinching of hands, fingers, and a design that eliminates corners, thereby alleviating impact during contact.

